

Item	Part No.	Qty.	Description
1	A0-P001-001	1	Safety latch
2	A0-E011-026	1	Set, Limit Switch
3	A1-S350-042	1	Handle door lock
4	A1-S350-005	1	Bracket, Front door (Color : PU-RAL 5015)
5	A1-S350-003	1	Glass retainer
	A0-A003-028	1	Tempered
6	A1-S350-035	2	Seal plate, Front-Rear
	A1-S350-036	1	Seal flat plate
	A0-A005-005	2	Seal, V-Ring,
7	A0-A004-007	2	Bearing
	A0-A006-012	1	Adapter sleeve
	A0-A005-035	2	Seal, O-Ring
	A0-A005-021	2	Seal, Oil

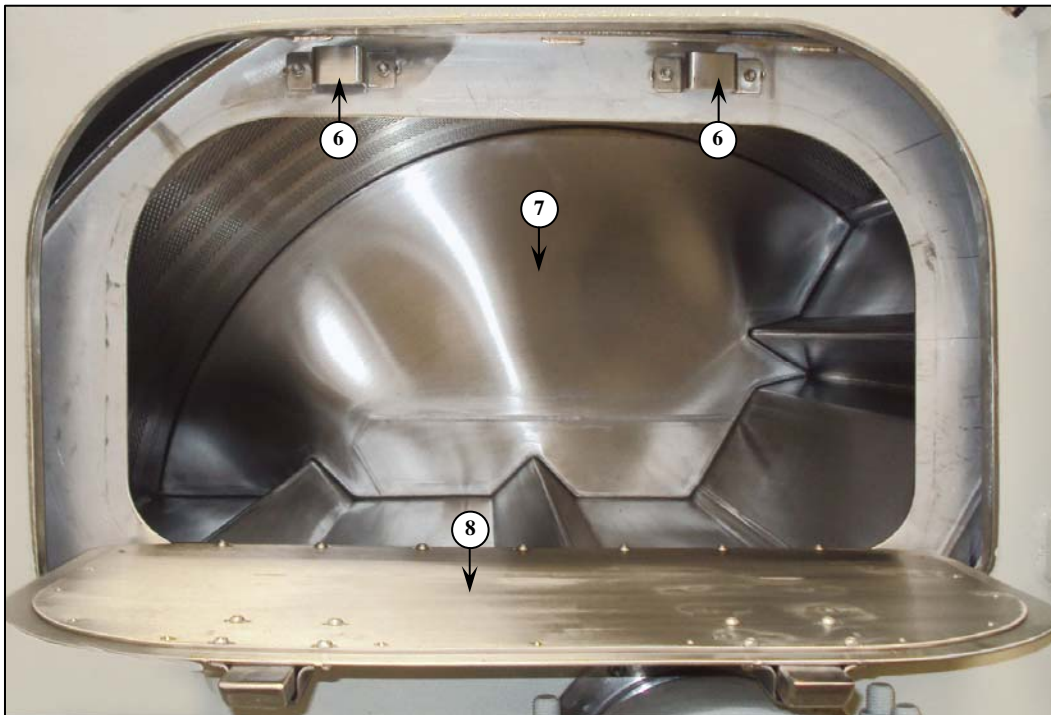

Item	Part No.	Qty.	Description
1	A1-S350-010	1	Basket door plate
2	A1-S350-012	6	Fastener
3	A1- S350-011	1	Hinge, Basket door
4	A1-S350-006	1	Plate, Outdoor (Color : PU-RAL 5015)
5	A0-A018-303	1	Door seal (Silicone)
6	A1-S350-030	2	Lock, Fastener
7	A1-S350-013	1	Basket stainless steel assembly
8	A1-S350-010	1	Basket door plate

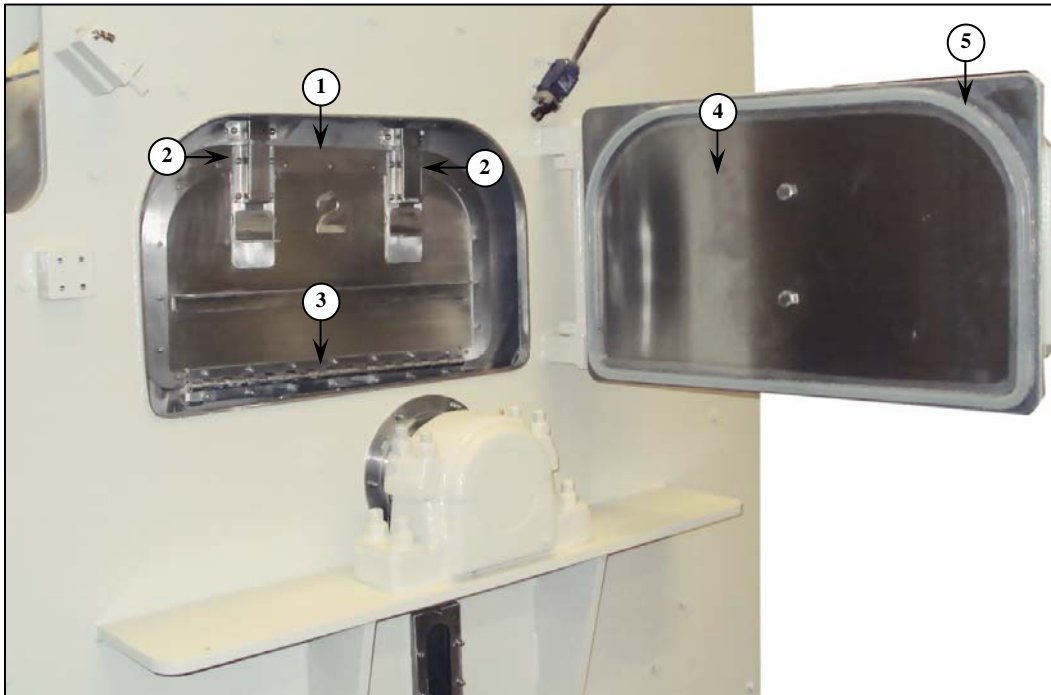
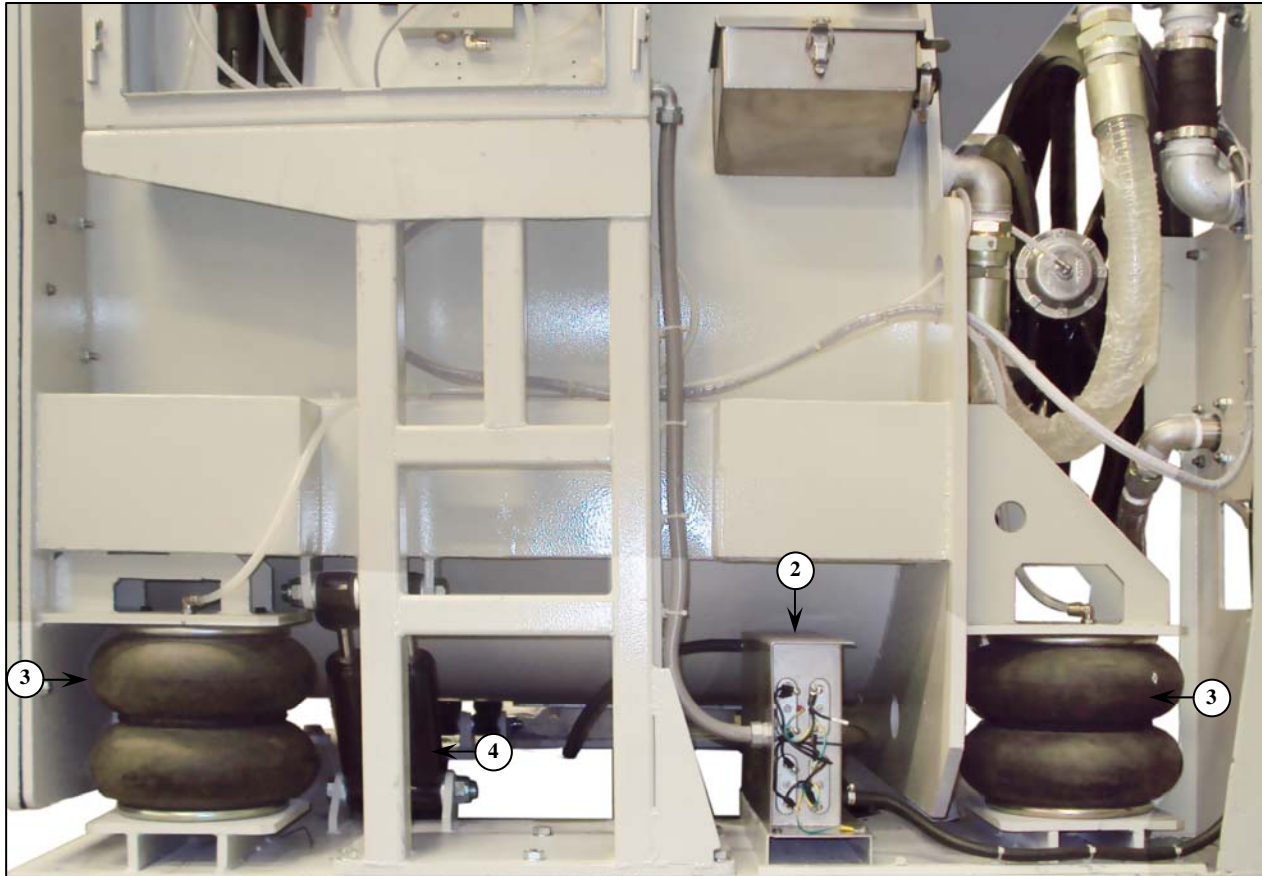
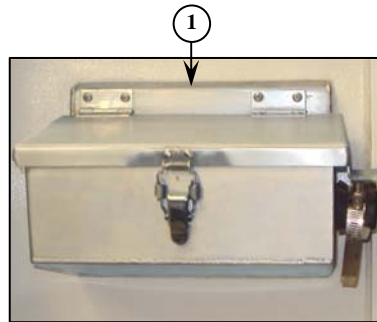

Item	Part No.	Qty.	Description
1	A1-S350-045	1	Supply dispenser
	A1-S350-046	1	Supply dispenser cover
2	A0-E005-004	1	Heating Element , 2600W, 240V, 50/60HZ
	A1-S350-055	1	Heating element box
3	A0-P002-003	4	Air cushion 12", 2 Levels
4	A0-A031-120	3	Medium Shock Absorber

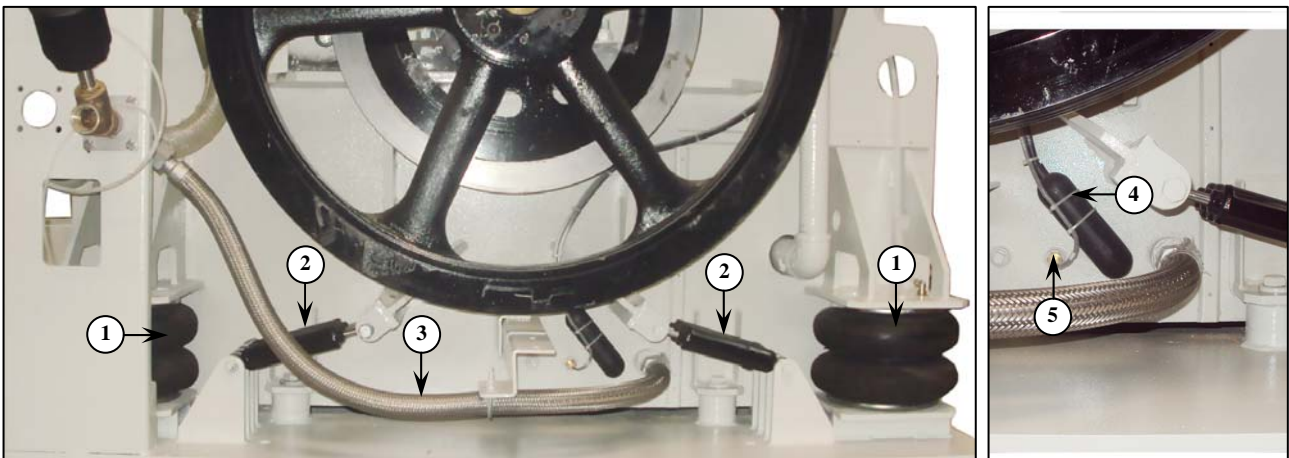
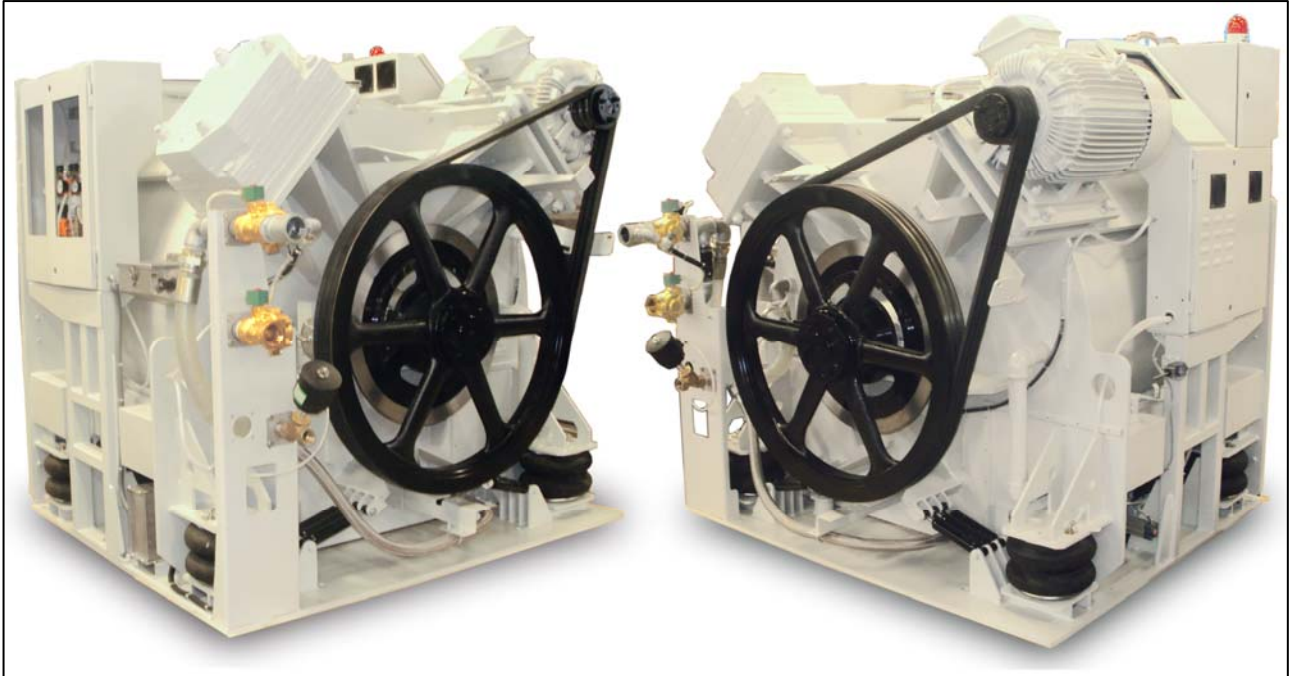

Item	Part No.	Qty.	Description
1	A0-P002-003	4	Air cushion 12", 2 Levels
2	A0-A031-120	6	Medium Shock Absorber
3	A0-A017-102	1	Flexible 1-1/4" X1000 MM.
4	A0-A018-091	1	Hose, Water Level 1-1/2"
5	A0-E027-007	1	EL6, Temperature probe

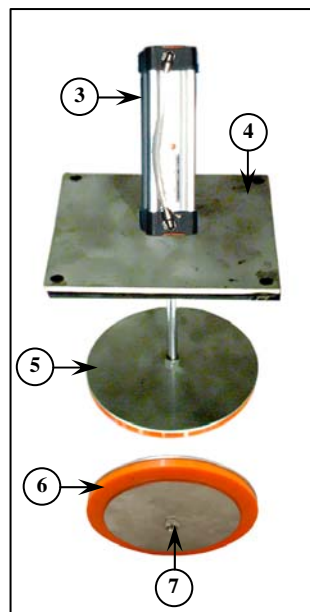
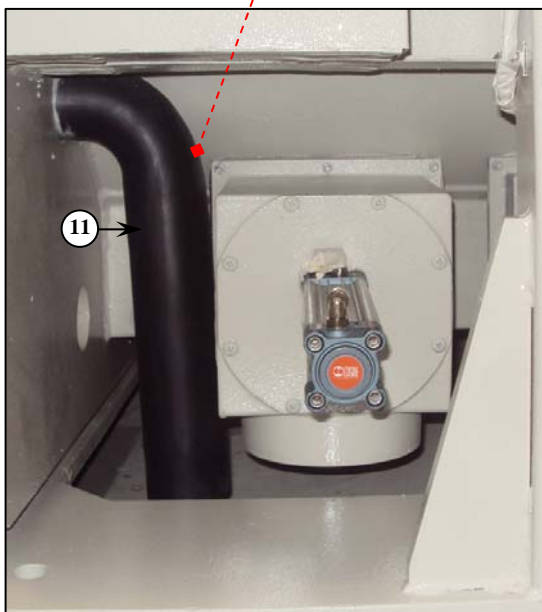
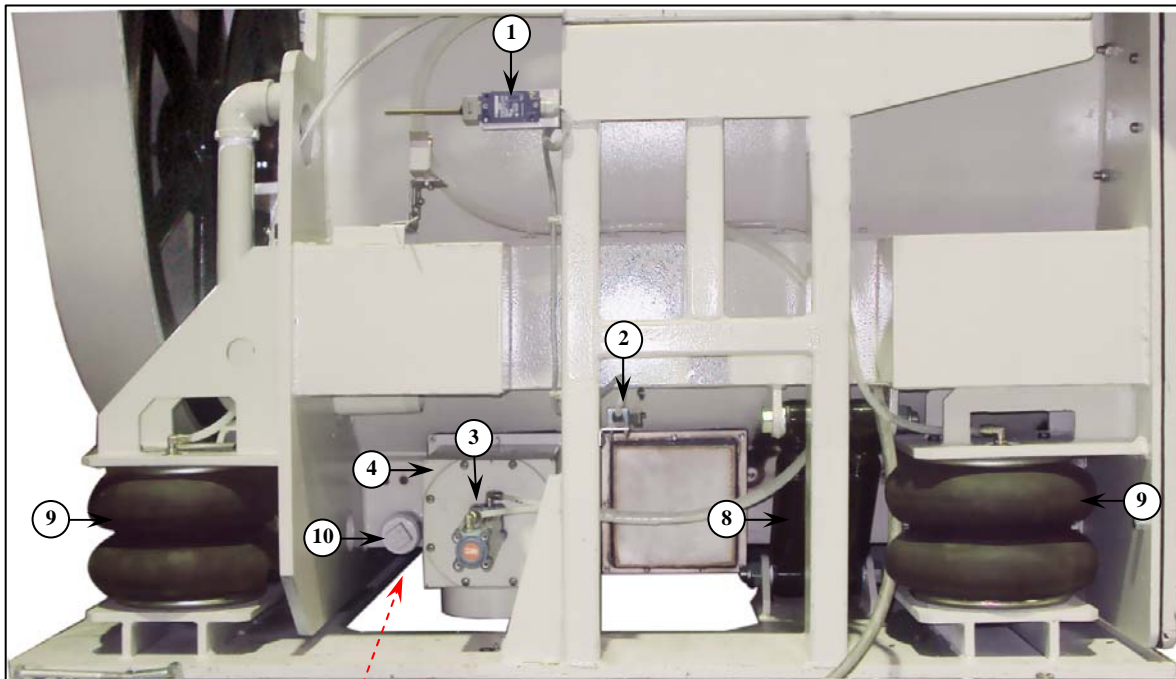

Item	Part No.	Qty.	Description
1	A0-E011-027	1	Set, Limit Switch
2	A0-E011-033	1	Limit Switch Variable Length
3	A0-P003-066	1	Air cylinder
4	A1-S350-041	1	Drain air cylinder mounting plate
5	A1-S350-040	1	Seal backing plate
6	A0-A001-047	1	Drain rubber seal
7	A1-S350-039	1	Seal front plate
8	A0-A031-121	2	Large shock Absorber
9	A0-P002-003	4	Air cushion 12", 2 Levels
10	A0-A052-011	1	Clamp hose
11	A0-A018-051	1	Rubber hose

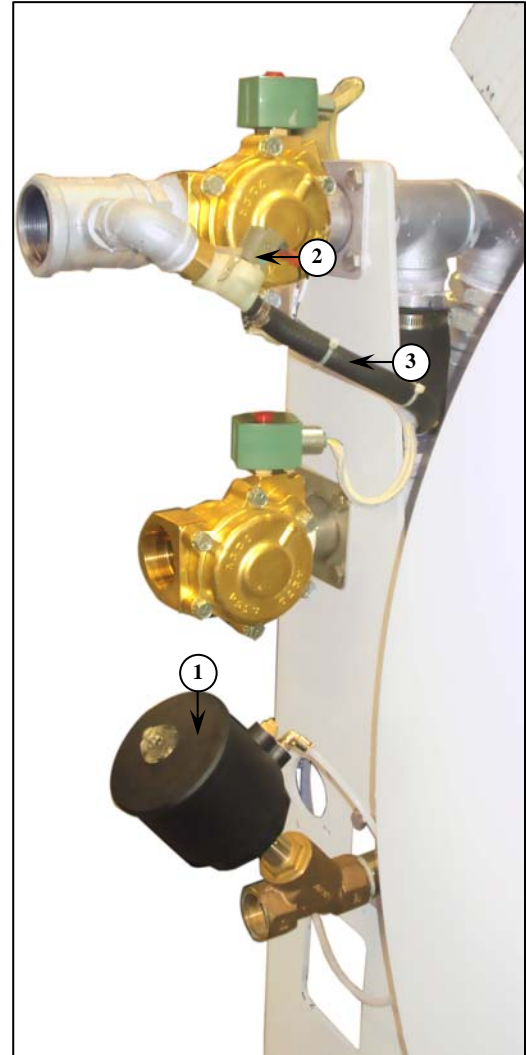
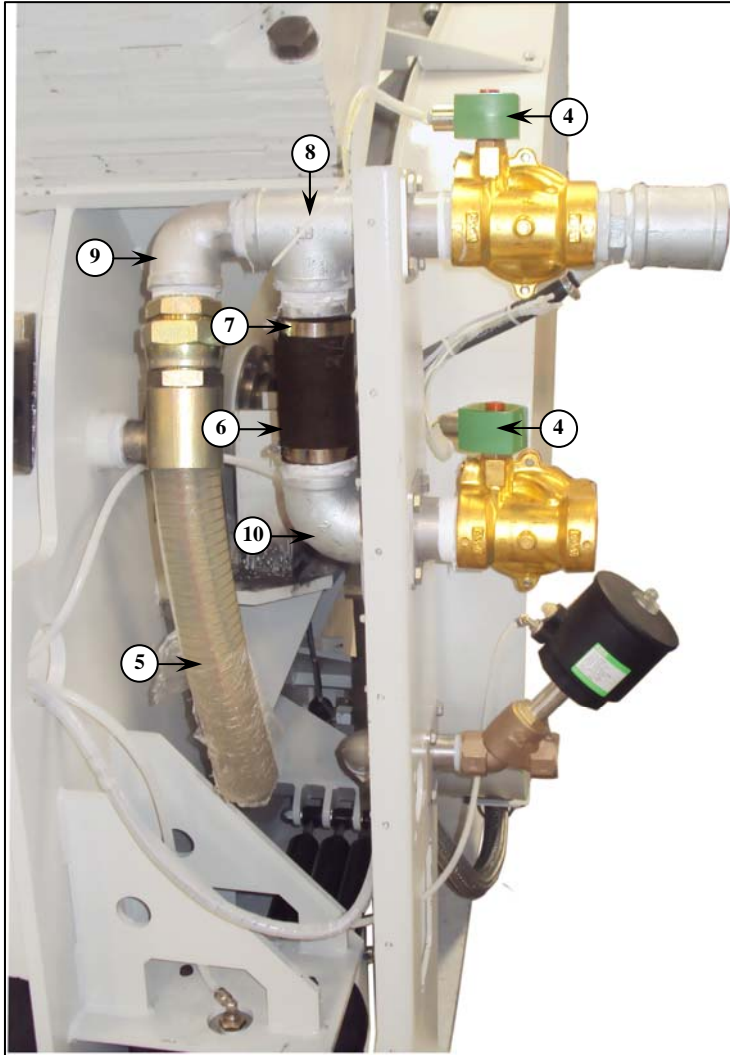

Item	Part No.	Qty.	Description
1	A0-E047-032	1	Piston Valve 2"
2	A0-E040-027	1	Valve Water 1-Way
3	A0-A018-016	1	Hose, Supply chemical
4	A0-E047-074	2	Solenoid Steam Valve Size 1" 24V/50HZ
5	A0-A018-318	1	PVC spring 2"x100CM.
6	A0-A018-021	1	Drain hose
7	A0-A052-007	2	Clamp hose
8	A0-A088-032	1	3 -WAY , 2"
9	A0-A009-069	1	Elbows male/female 2"
10	A0-A009-006	1	Pipes elbow 90° 2"

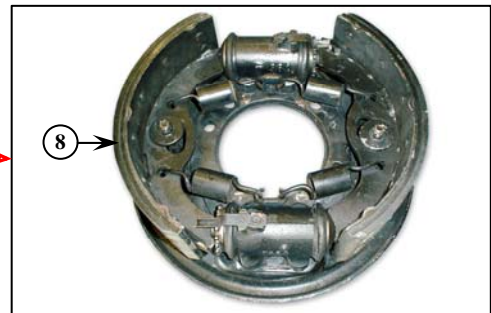
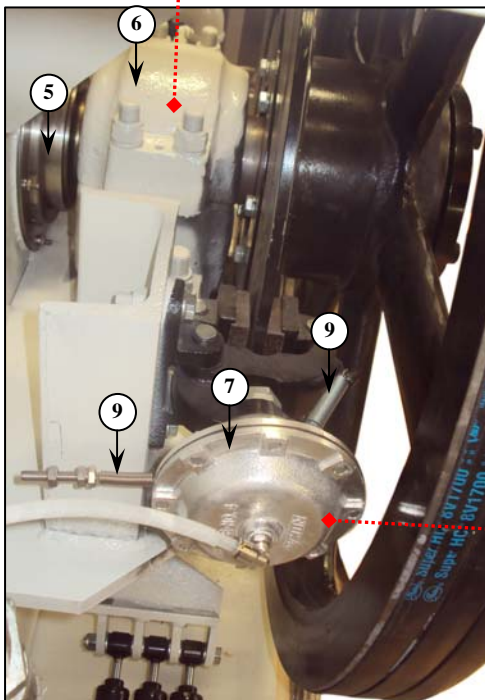
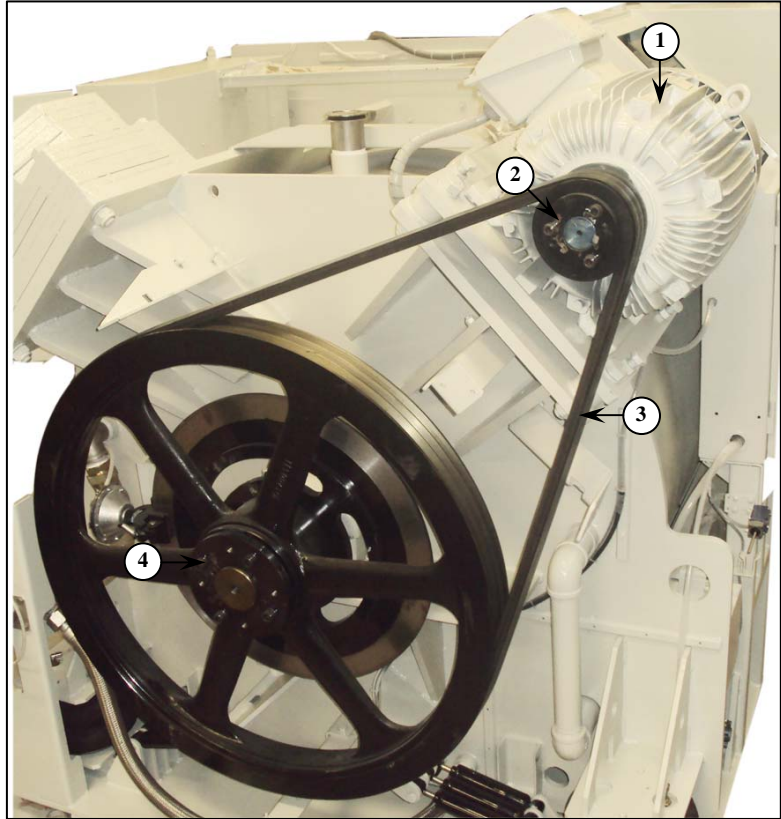
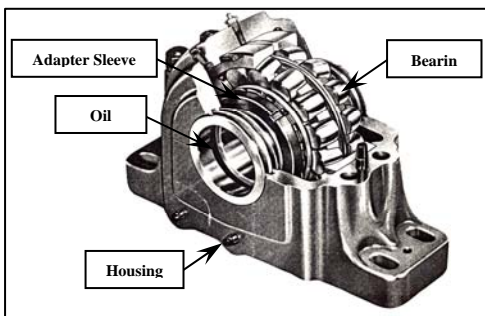

Item	Part No.	Qty.	Description
1	A0-E008-315	1	Motor 30HP. /6P. /190,380V. 60HZ. /3PH.
2	A0-M008-108	1	Motor pulley
3	A0-TSAN01-850	3	V-Belt
4	A0-M008-107	1	Basket pulley
	A0-M009-009	1	Basket pulley bushing
5	A1-S350-035	2	Seal plate, Front-Rear
	A1-S350-036	1	Seal flat plate
	A0-A005-005	2	Seal, V-Ring,
6	A0-A007-005	1	Housing, Rear
	A0-A004-007	2	Bearing
	A0-A006-012	1	Adapter sleeve
	A0-A005-021	2	Seal, Oil
	A0-A005-035	2	Seal, Oil
7	A0-TSA01-1590	1	Air Brake Complete set
8	A1-S350-020	1	Brake pad complete set
9	A0-A008-111	2	Spring

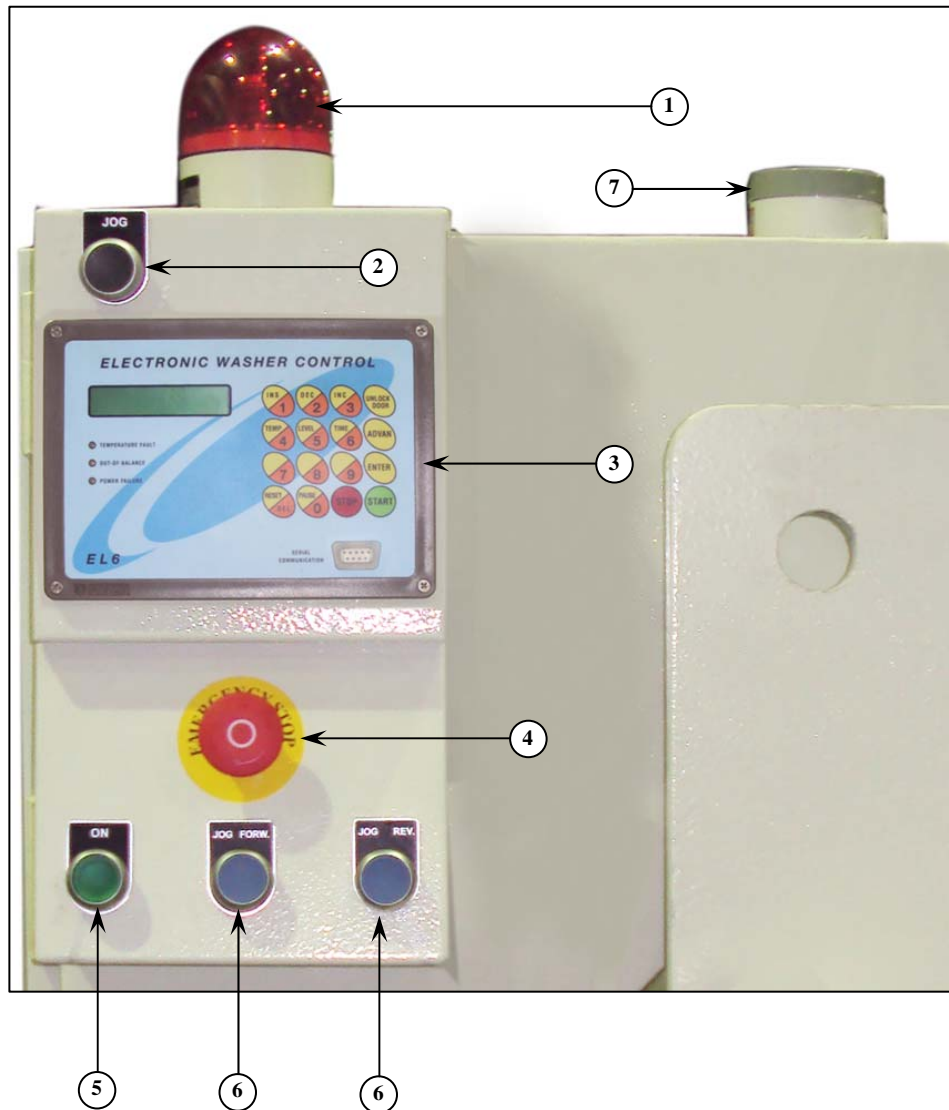

Item	Part No.	Qty.	Description
1	A0-TSEN01-408	1	Warning Light Patlite
2	A0-E032-004	1	Push button switch (Black)
3	A0-E007-005	1	EL6 Control
4	A0-E032-018	1	Emergency stop
5	A0-E032-009	1	Push button switch (Green)
6	A0-E032-003	2	Push button S.W. (Blue)
7	A0-E042-002	1	Buzzer bell 24 VDC

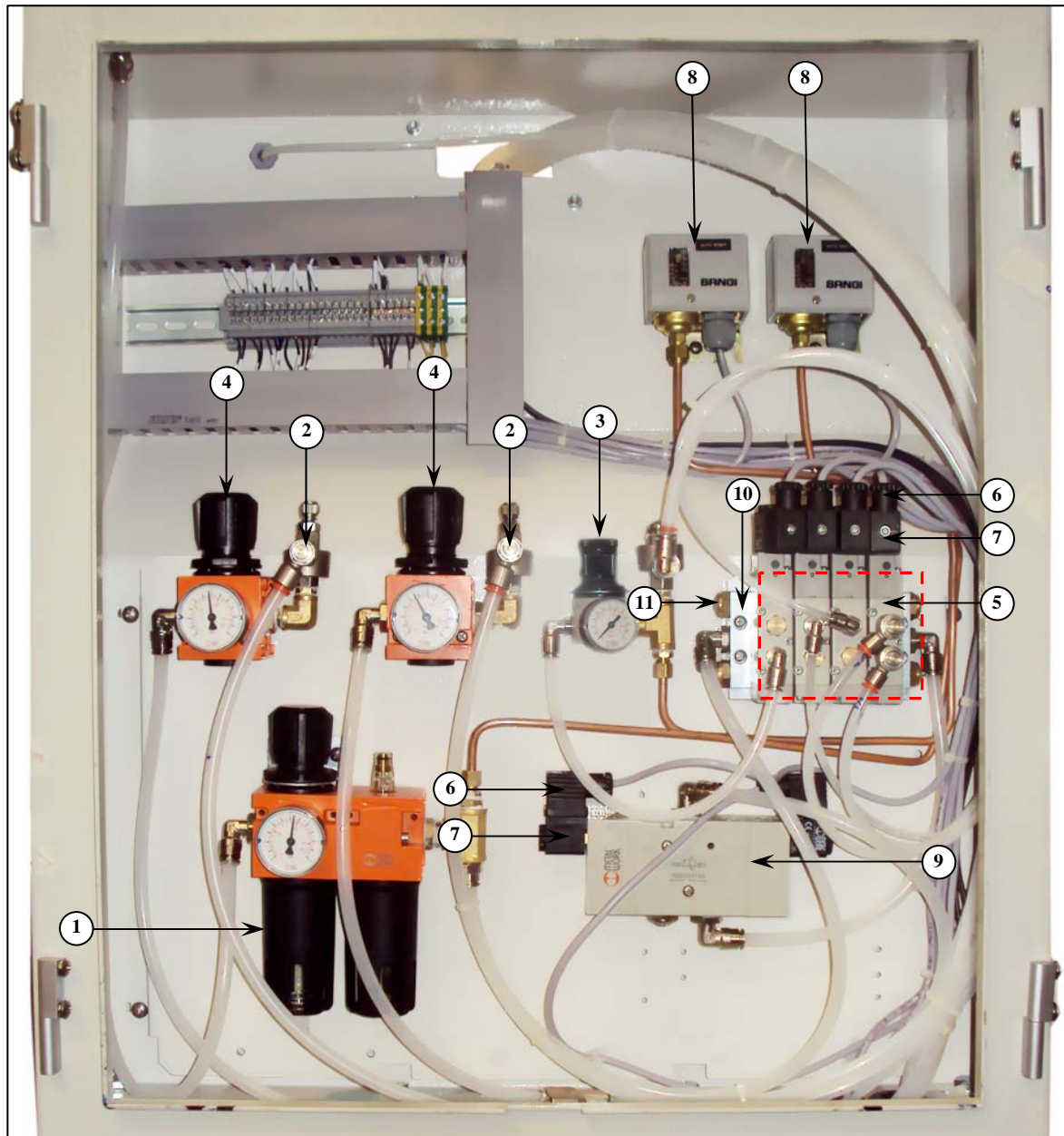

Item	Part No.	Qty.	Description
1	A0-P004-020	1	Regulator assembly
2	A0-P008-007	2	Quick exhaust Valve
3	A0-P004-021	1	Regulator 1/4"
4	A0-P004-023	2	Regulator
5	A0-P005-137	4	Valve, Air solenoid
6	A0-P005-181	6	Coil Connector
7	A0-P005-180	6	Coil, Air Solenoid Valve
8	A0-E018-020	2	Pressure switch
9	A0-P005-078	1	Air Solenoid
10	A0-P005-150	1	Kit Base For Air Solenoid
11	A0-P006-016	4	Silencer

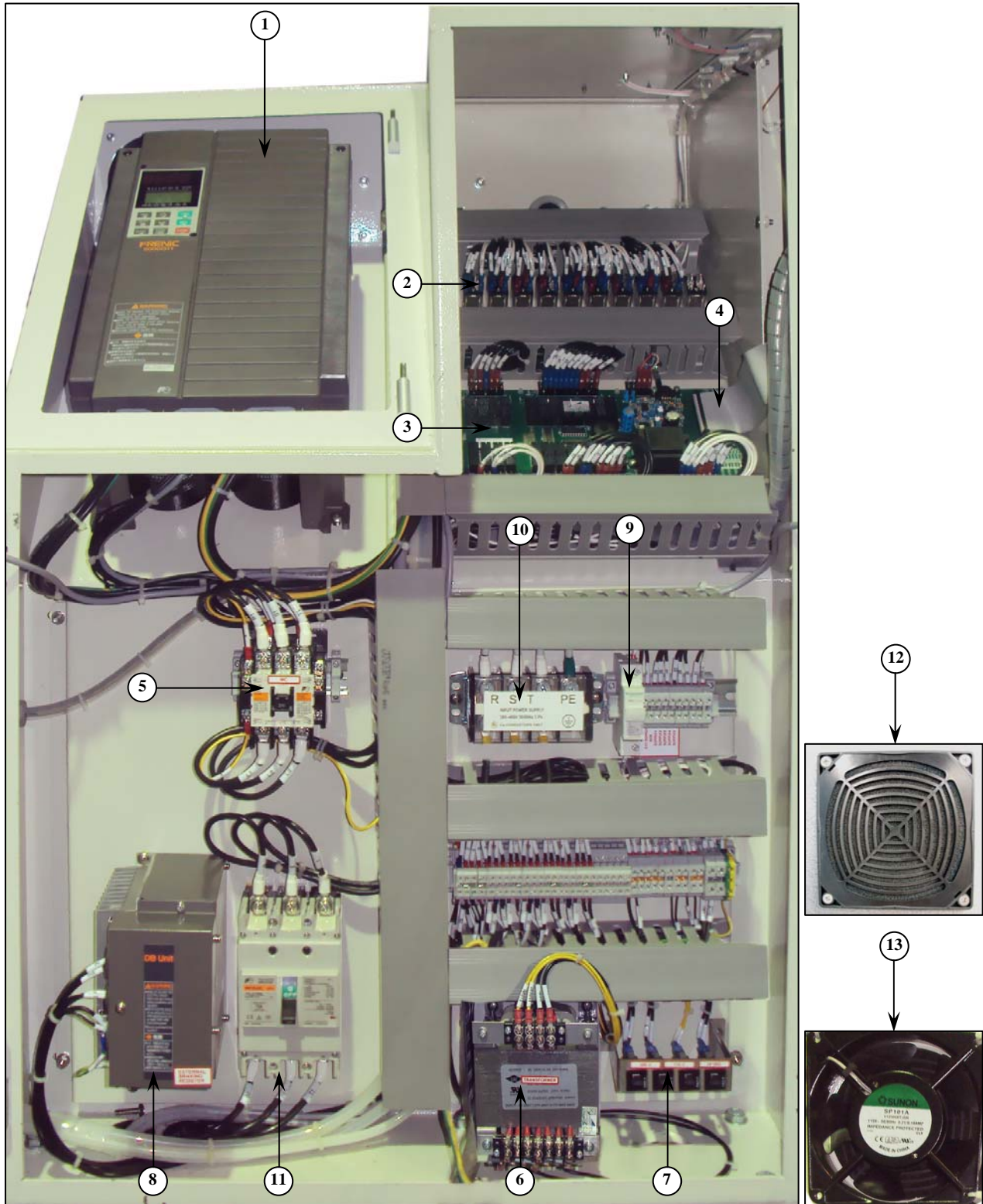

Item	Part No.	Qty.	Description
1	A0-E001-916	1	Inverter 30HP, 430V.3PH.
2	A0-E009-017	10	Relay, 24VAC 50/60HZ
3	A0-E007-005	1	EL6 Control
4	A0-E007-028	1	Harness, cable 40 PIN
5	A0-E004-076	1	Magnetic contactor coil 24VAC

Item	Part No.	Qty.	Description
6	A0-E006-032	1	Transformer 50/60 HZ
7	A0-E010-029	1	Circuit breaker 250V, 50/60HZ, 6A
	A0-E010-034	2	Circuit breaker 250V, 50/60HZ, 3A
	A0-E010-035	1	Circuit breaker 250V 50/60HZ 2A
8	A0-E002-020	1	Breaker unit (25HP,30HP)
9	A0-E010-068	1	Breaker Fuse 2A
	A0-E022-011	1	Fuse 1A
10	A0-E021-142	1	Terminal 4P. 600V, 100A
11	A0-E010-079	1	Circuit Breaker Manual Start-Stop
12	A0-E012-009	1	Fan, Filter
13	A0-E012-008	1	Fan, Cooling 115 VAC

